



# KUNSTOR.

## K10 USER'S MANUAL

**Please be sure to watch operation video**

Video, Manuals, software inside TF card



русская версия в карточке

Die deutsche Version ist in der TF Karte

La versión en español está en la tarjeta TF

한국어 버전은 TF 카드에 있어요.

La version française est sur la carte TF

La versione italiana è nella scheda TF

A versão em português está no cartão TF

De Nederlandse versie staat in de TF kaart

Polska wersja znajduje się w karcie TF

Wersja szwedzka jest w karcie TF

日本語版は TF カードに入っています

# 1, Printer Specifications

## 1.1 Main Part

filament holder can only hang 250g filament

If you want to hang 500g filament, you can print an extension bracket , (Contact after sales service team to get the Gcode file of the bracket)

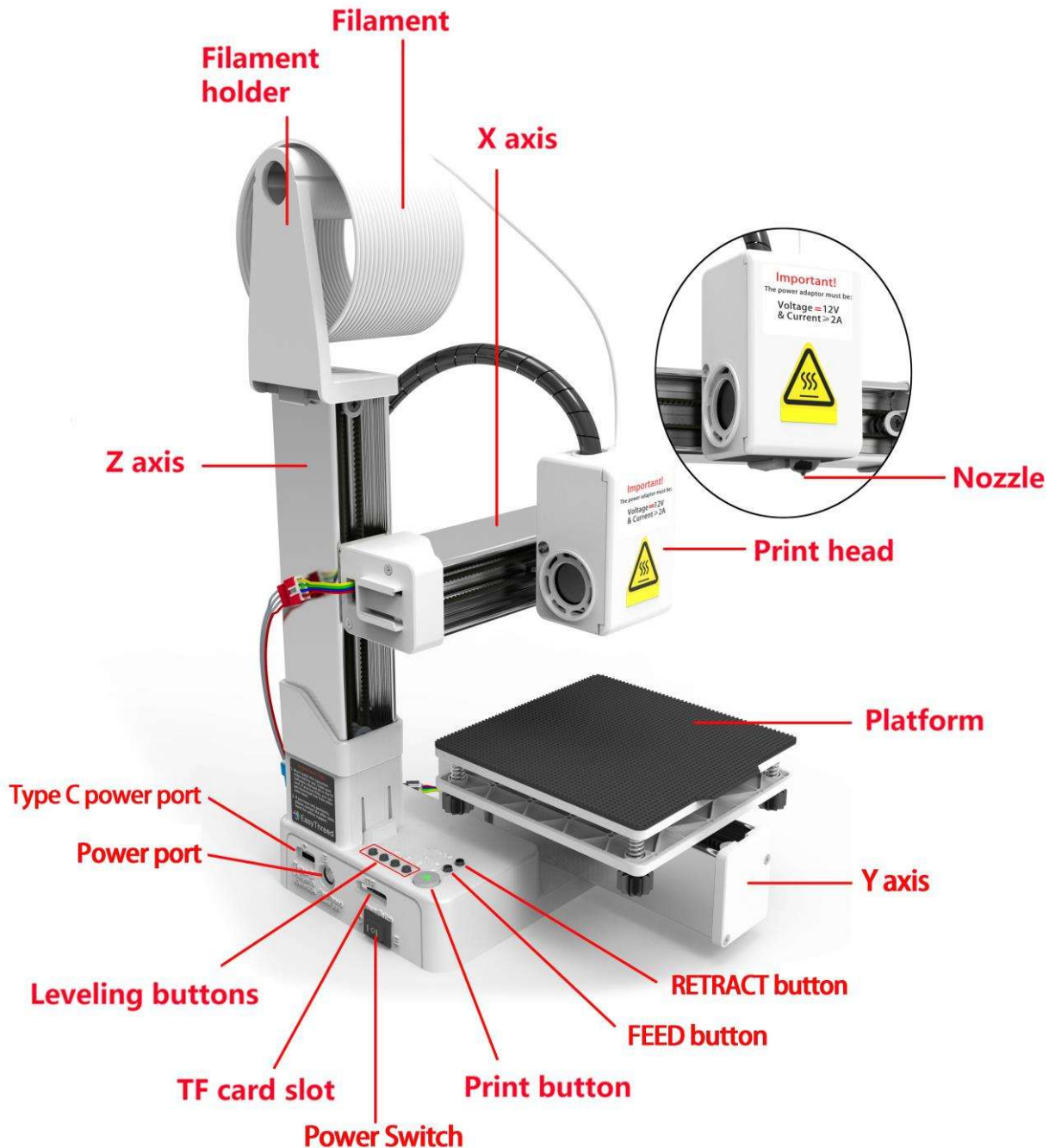

If printer not equipped with power adaptor, Your power adaptor must be:

Voltage=12V&Current $\geq$ 2A, Port : Type C

## 1.2 Basic Parameter

Nozzle diameter: 0.4 mm

Compatible filament: PLA TPU 1.75mm

Nozzle temperature: 180-230 °C

Print speed: 40mm/s

Layer thickness: 0.05~0.3mm

Print size: 100 \* 100 \* 100mm

Print format: gcode

Slicer software: Easyware, CURA

**(Very important: If you use CURA slicer, you must do same as our CURA set teaching video!!! add printer to CURA first , otherwise printer can't print it)**

## 2, Un-Boxing and Install.

2.1 Inside is an 3d printer , 10M filament,, TF card, card reader, screw driver. Filament holder.



X Z Axis, same



Control box and print head



Y Axis and Platform



Z Axis support



screwdriver



Filament holder



TF card, Card reader



10M PLA filament

## 2.2 Install the Printer (**Watching video is easier to operate**)

Installation sequence 1234567, Watch video

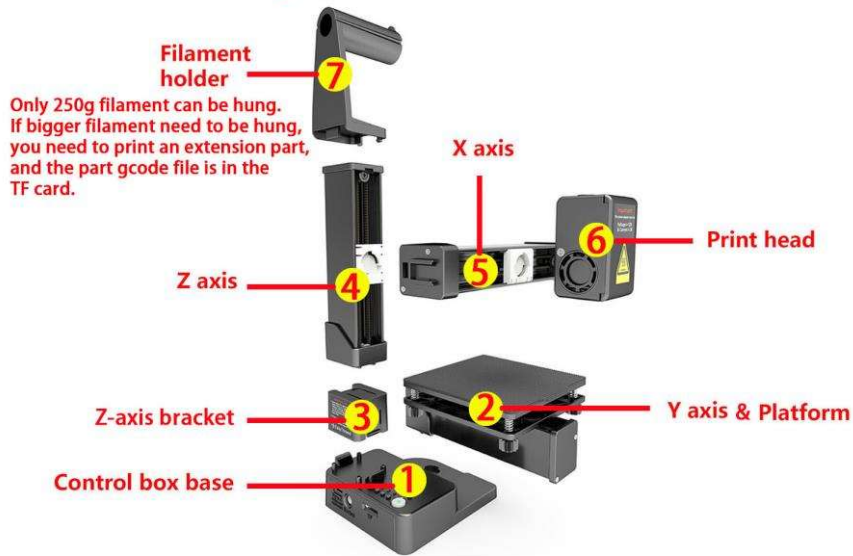

Step1, Install Y axis&platform to Control box base,1&2.



Step2, install Z axis support 3.

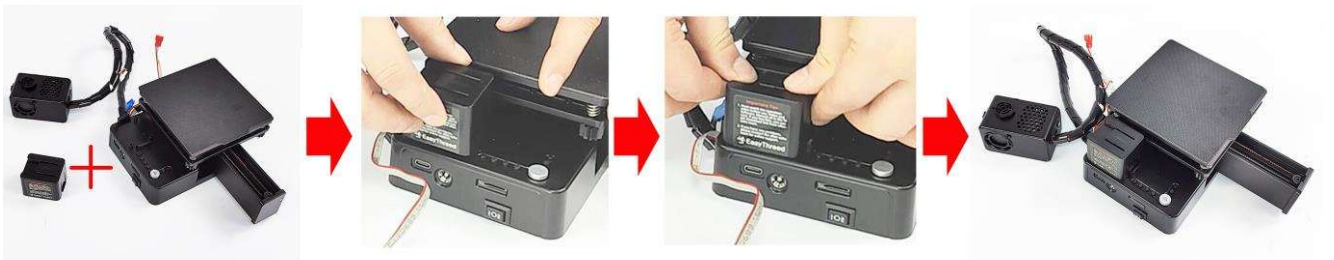

Step3, Install Z axis 4, push to end.

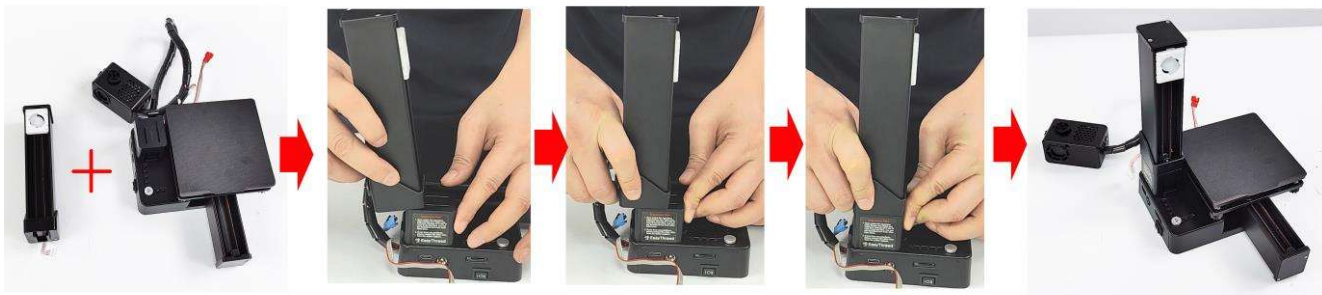

Step4, install X axis 5.

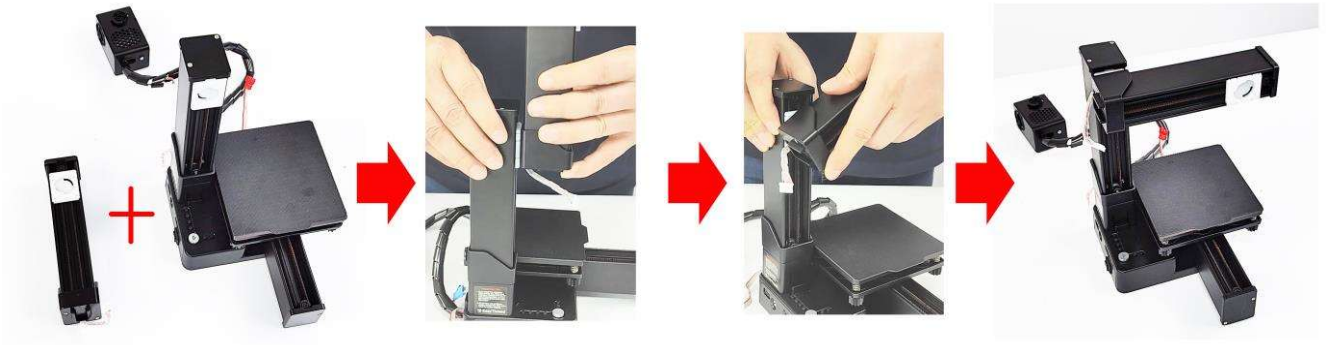

Step5, Install print head 6.

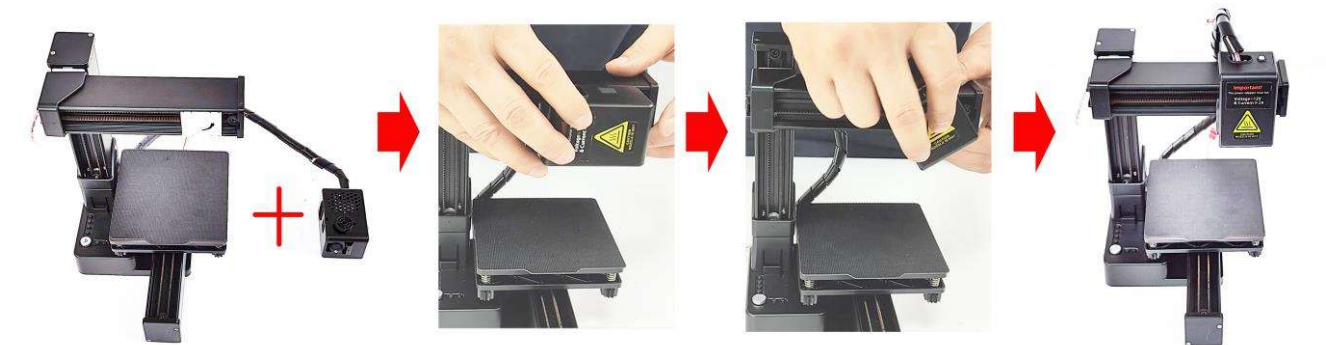

Step6, Install filament holder 7.



Step7, connect XYZ motor wires. Red is for X, Blue is for Z axis, Black is for Y axis

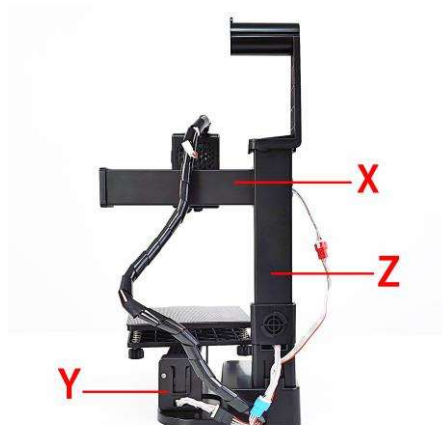

### 3, Power on

(If printer not equipped with power adaptor, Your power adaptor must be:

Voltage=12V&Current $\geq$ 2A, Port : Type C

Connect power, and press the switch, the light of print button  is on.

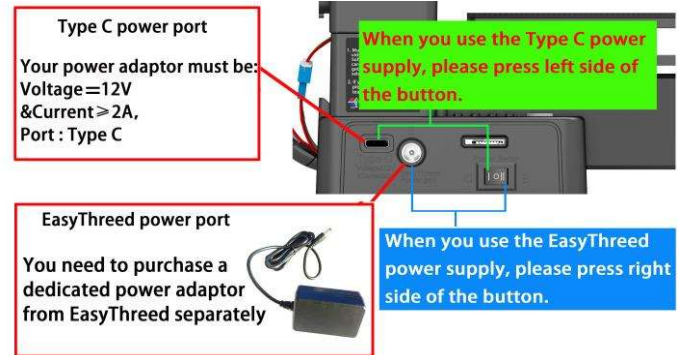

**Do not move the XYZ axis by hand when the power is on**

### 4, Slicer software application (STL format 3D file need be sliced to gcode format that printer can recognize).

- (1). This 3D printer runs with its own developed slicing software named Easyware, it is in the TF card included, please copy it to your computer (no need installation), you can also download Easyware from official website, Slicer operation teach video inside TF card as well. Easyware slicer can recognize STL format 3D file. (if you want better printing effect, you can learn to use CURA slicer, we supply software and teach video inside TF card)
- (2). STL format 3D file need be sliced to .gcode format, and save to TF card, and Insert TF card to printer, then can print 3D file. **3D Printer will print the latest gcode file, gcode name can be only English or letters, without special symbols**

**Warm Notice: there is a initial test gcode file inside the TF card.**

### 5, Print

( 1 ) **Platform Leveling**, The first time to use this printer, you need leveling the platform

Please adjust the distance between the nozzle and the platform in

① ② ③ ④ points, the distance should be just the thickness of a sheet of paper, when you put a paper under the nozzle and pull the paper, **There is a feeling of friction when pulling the paper.** ( Please do this leveling with the help of adults.)



a), **Firstly put a piece of paper on the platform, the paper a little larger than the printing platform.**

b) Press the leveling buttons 1, and the print head will automatically move to the ① position of the platform. The 1, 2, 3 and 4 on the leveling buttons will match the ①, ②, ③ and ④ on the platform.

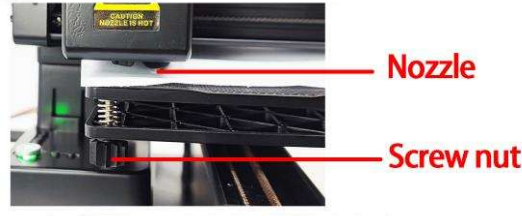
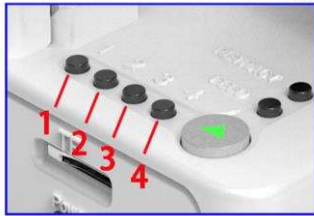

c) Adjust the screw nut at the bottom of the platform (as shown in the figure below ,loosen the nut, the platform rises, tighten the nut, and the platform falls). Adjust the height of the platform through the nut so that the gap between the nozzle and the platform is just one sheet of paper thickness (about 0.1mm). **When the paper is gently pulled, there is obvious friction**

**between the paper and the nozzle, the nozzle will not damage the paper.**

**Note: When adjusting the nut, do not press the platform with your hand to avoid affecting the accuracy of leveling.**



d) After the ① point is adjusted, press the leveling buttons 2, and do the same steps above to complete the leveling of the ② position. After that, use the same method to continue to complete the leveling of ③ ④ points.



e) If there are still print problems, you can repeat the whole leveling work 1-2 times.

**Leveling completed !**

## (2) Load Filament , feed

**before feed, you need make sure there is at least 3cm space between the nozzle and the platform** (Press print button hold for 3 seconds and release, the printer head will raise 1cm each time),

- Straighten the front end of the filament about 2cm ,Insert filament into the insert tube until it can not go further, and press the filament with a little force to keep it.
- Press the button “FEED” on the printer, and the light of the print button will start to flash. At the beginning, it will flash quickly to indicate that the nozzle of the printer is heating. When the temperature reaches, the light will flash slowly. After the slow flash, the feeding gear will start to turn and roll the filament into the nozzle. The whole process needs to be pressed by hand to ensure that the filament can be caught and rolled in by the gear. When the nozzle mouth has uniform filaments come out, it means that the feeding is successful, The whole feeding process takes about one minute. After the feeding is successful, you can press the button “FEED” again to end the feeding.

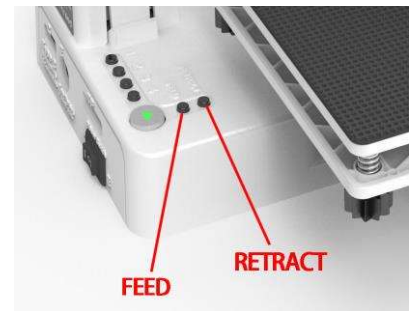

- The front end of the filament must be straight.
- During the whole process of feeding, please press the filament down with a little force by hand, so that the gear can catch the filament until the nozzle starts spinning and then let go.
- The print button light is blinking fast means nozzle heating up, When the light blinking slow. The gear starts to turn and draw the filament into the nozzle.



**Feeding failure reason normally :**

- (1) The front end of the filament is not straight;**
- (2) Didn't keep pressing the filament with a little force during the whole process.**

**Feeding failure reason:**

1. The front end of the filament is not straight.
2. Didn't keep pressing the filament with a little force.

## (3) Print

Insert the TF card with gcode file (the direction of the TF card should be correct as shown in the figure below), press the print button , and the light on the print button will start flashing after the printer reads the gcode file, and the nozzle will start heating. **Please wait patiently for about one minute.** When the temperature reaches, the printer will start printing. (Note: The printer only prints the latest gcode. The gcode file name can only use English letters or numbers.) **There is a gcode test file in the TF card, which is directly printed for the first time.** **Don't press the print button repeatedly!!!**

The TF card insert with right direction



If first time the initial gcode print good, means the printer is good, if you can't print other gcode, then means your gcode has problem , you need get correct gcode according to your slice teach video.

You can contact our after-sales team to help you.

#### (4) Pause/Restore

during printing, Click print button  ,the button light stops flashing , then printing paused.

If need to continue print , Click print button  again to restore, the button light flashes again , the printer will print again .

#### (5) Stop Print

If you want to stop print during printing , press print button  hold for 3 seconds then release , the machine will stop printing, then printing cancelled.

#### (6) Unload Filament,Retract

If you want to change a filament or do not print for a long time, you need to withdraw the filament from the nozzle, press the **“RETRACT”** button, the light of the print button will flash, pull the filament up gently by hand, please wait patiently, you will feel that the filament will enter a little before exiting, and the whole process will take more than one minute. After the material exits the print head, press the **“RETRACT”** button again to finish.

**After print ,remove the platform, and easy to take off the object.**



**High quality filament which is preferred to be used.**

Various of filament are available on the market , and quality is much different too. poor quality filament may cause broken or nozzle jam, Pls choose Easythreeed high quality filament.



#### **Safety Warning**

Burning , keep your fingers away from the **NOZZLE** and **BLACK INSULATOR** when the printer is working as temperature in this area reaches over 200 Celsius degree . Always be sure to keep your hands away from moving parts when it is working .

## 6. Maintenance

- 6.1 Do not use the methods that is not mentioned in this manual to disassemble or modify this machine , to avoid damage to this printer or may cause other serious accident .
- 6.2 When the power is off , regularly clean the machine with a piece of cloth to wipe off dust and residue , if the cloth is wet , do not use inflammable liquid to contact the inner circuit to avoid fire or electronic shock .
- 6.3 When printing finished, clean the residue in nozzle and extrude , to avoid nozzle choke for next printing , it is also basic maintenance.
- 6.4 Recommended temperature for working environment is 5°C-35°C, do not air the machine body with a fan